

TT5 SERIES

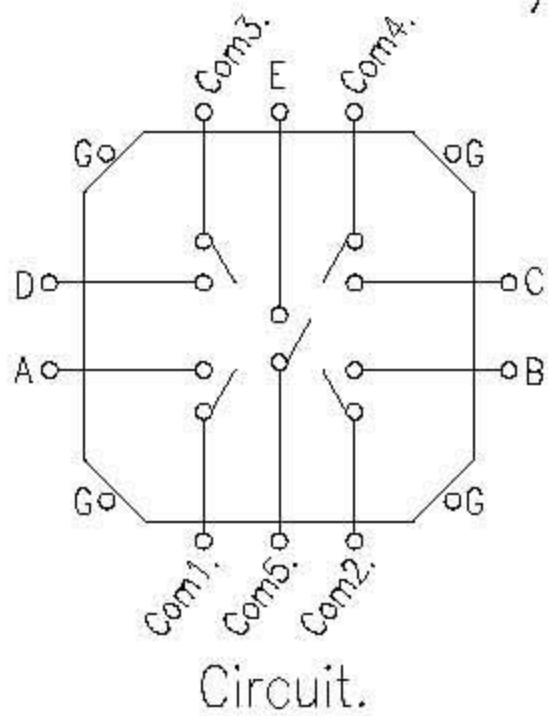

DIMENSIONS

TT5

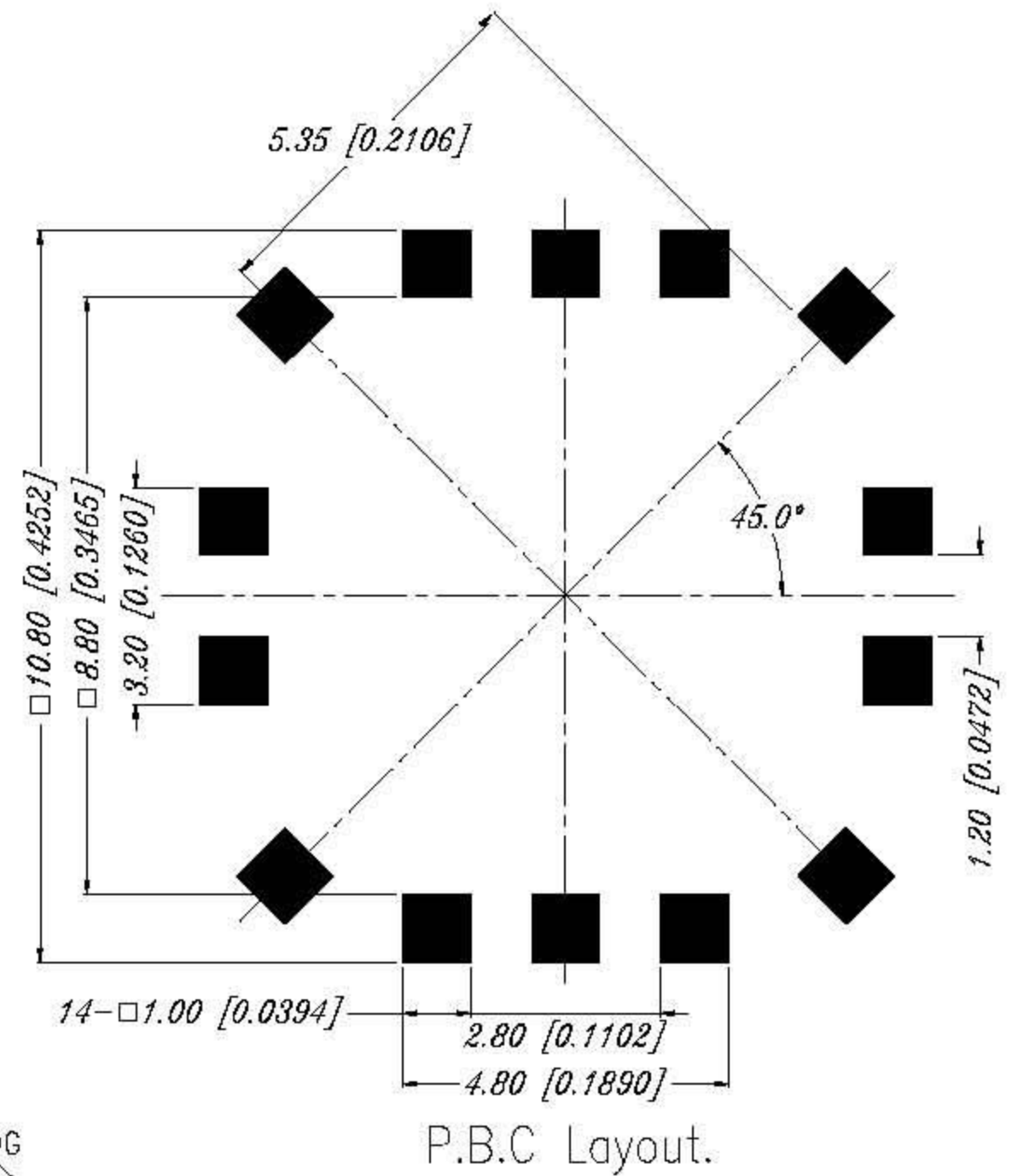
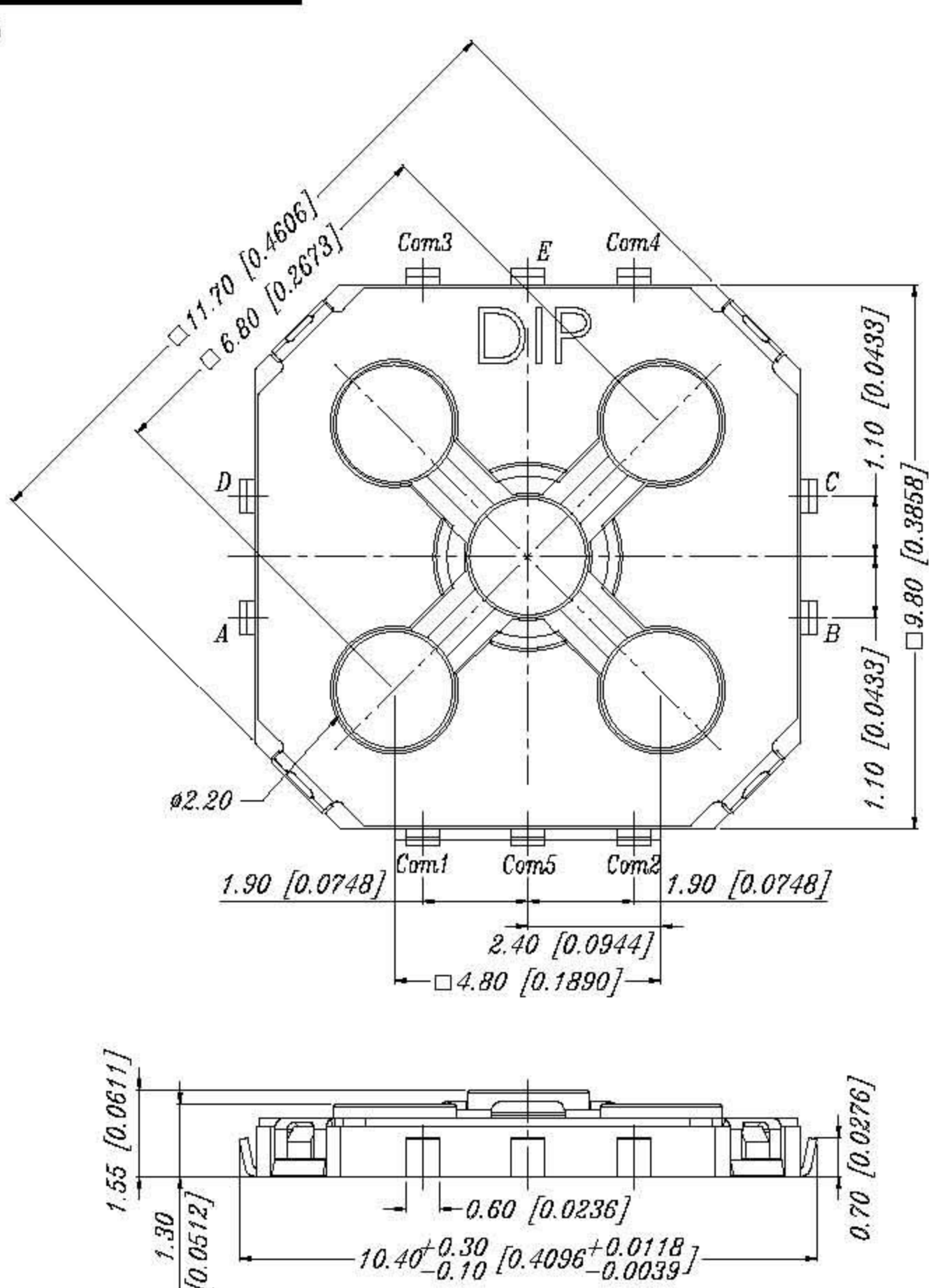

General Tolerance : $\pm 0.2\text{mm}$

HOW TO ORDER

TT5 - □ - □

Package :
 T/R = Tape & Reel
 B = Tube

Soldering :
 V = Lead Free Solderable

Thinner Multi Function Tact Switch

SPECIFICATION

△MECHANICAL

Operation Force : Side : 180 \pm 60gf
 Center : 320 \pm 80/-60gf
 Stroke : 0.25 \pm 0.15mm
 Operation Temperature Range : -20°C to +70°C
 Storage Temperature Range : -40°C to +85°C

△ELECTRICAL

Electrical Life: 200,000 cycles
 Rating: 50mA, 12VDC
 Contact Resistance: 100m Ω max.
 Insulation Resistance: 100M Ω min. at 500 V DC
 Dielectric Strength: 250 VAC / 1 minute
 Contact Arrangement: 1 pole 1 throw

MATERIAL

△BASE : High-Temp Thermoplastic Nylon UL 94V-0
 △COVER : Nickel silver
 △STEM : High-Temp Thermoplastic Nylon UL 94V-0
 COLOR : BLACK
 △CONTACT Disc : Stainless with silver cladding
 △TERMINAL: Brass with silver plated
 △TAPE: Teflon

SOLDERING PROCESSES

△HAND SOLDERING : Use a soldering iron of 30 watts, controlled at 350°C approximately max 5 seconds.

△REFLOW SOLDERING: When applying reflow soldering, the peak temperature of the reflow Oven should be set at 260°C max.

△Reflow Temperature Profile:

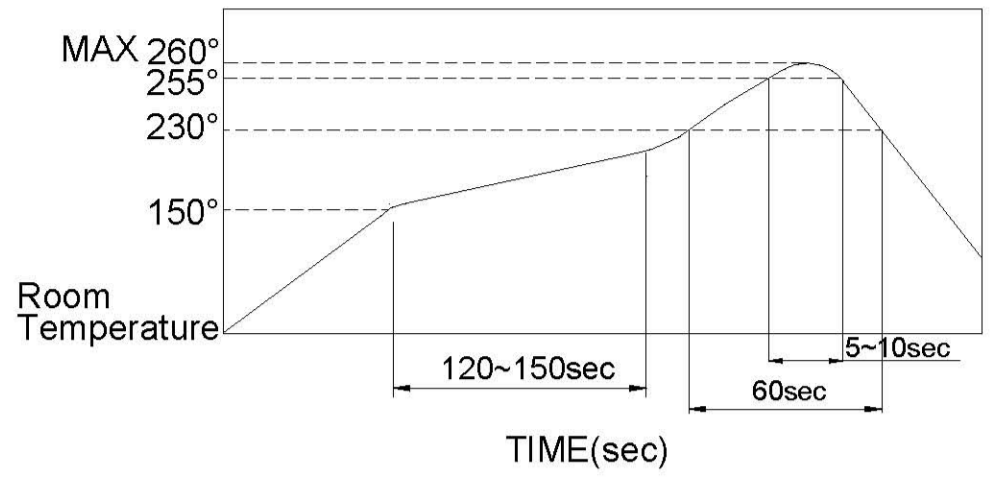

PACKING

Part Number	Number Per Tube	Part Number	Number Per Tube
TT5-V	-	2500	-

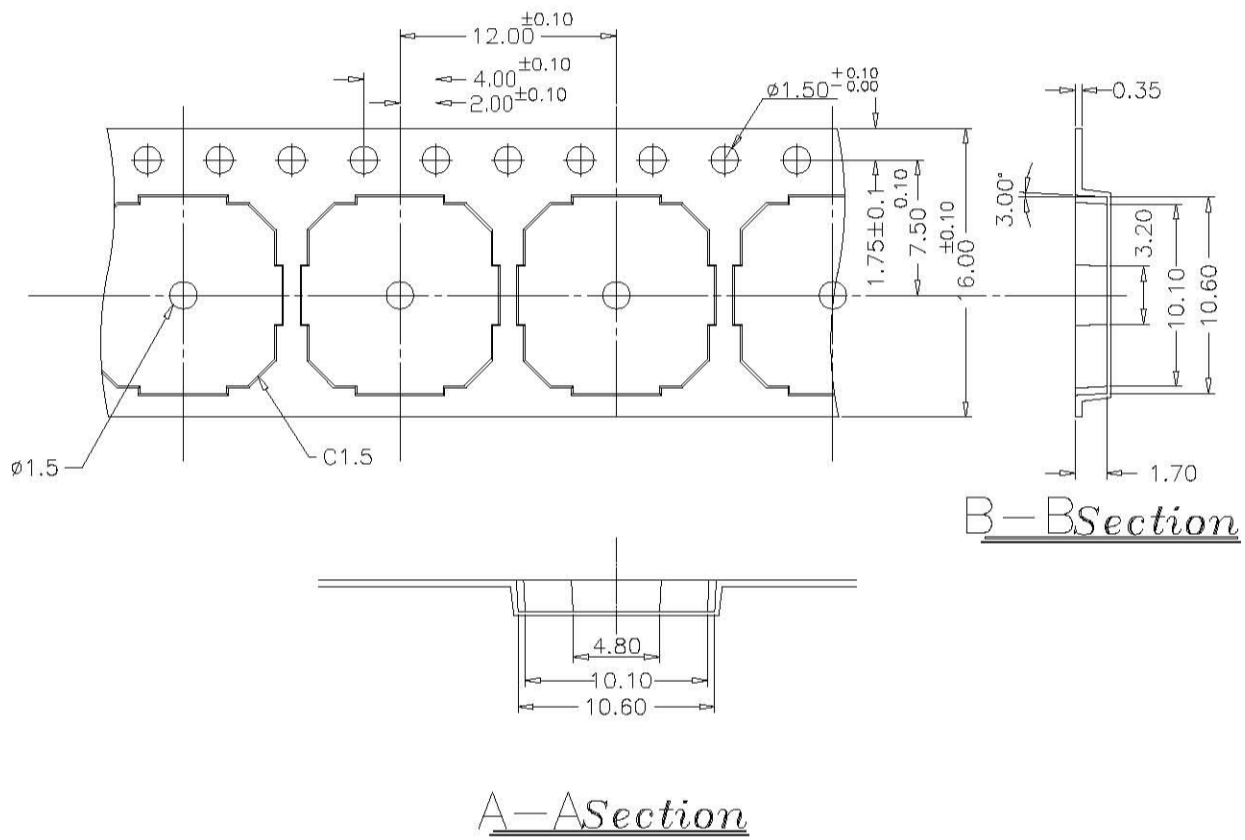

General Tolerance : ±0.1mm